

The Point

Performance Area: Small permanent stage with a front arc and perpendicular sides. SL side 5.5m
SR side 6.8m (it's shape can be best described as a wedge shape)

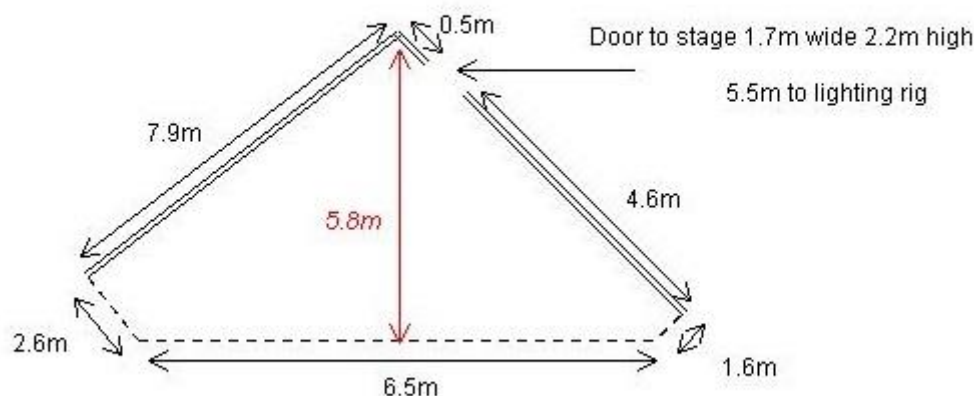

Removable bleacher seating in stalls to allow total flat floor area of approximately 160m²
Space seats 400 in rows and 250 – 350 in various cabaret styles
Fully standing 550

Surface: Strip sprung oak battens with 12mm hardboard painted black with Rosco show varnish

Access Access at level 1 via a goods lift (2m W x 3m D x 2.6m H) – and doors (2.6m x 2.6m) to rear of stage **No set storage is available.**

PLEASE NOTE: ARC has no dedicated parking for staff or visiting company vehicles.

Rigging Over stage rigging consists of a litebeam truss hung from 4 loadstar 500kg chain hoists
Maximum flying height >5m

Power Supply 125A 3 phase supply (Production Lighting)
63A single phase supply (Production Sound)Used for in-house PA system

Lighting 88 circuits run on Strand LD90 dimmers (80 X 10A/8 X 25A) with control via Avolites Pearl 2008/2500 channel desk at control position to rear of stalls
DMX network to DS/PS, Bridges 1 & 2 and FOH gallery
Independent circuits situated around stage area and Bridges 1 & 2, switched from control area (non dim)

House lighting is controlled via a 6 way Strand Premiere programmable push button

The Point

- 20 cp 62 parcans, 1000 Watt:
 - 3 point colours from each side of the stage
 - 3 point colours from the centre of the truss line
- 4 CCT freedom fresnels
- 4 LED Moving Heads Chauvet intimidator spot 350

- Front of house venue bridges comprises of:
- 6 CCT freedom PC`s with barn doors
 - 3 Strand Cantata 22/40 profiles on Rear Wall
 - 12 CP62 parcans 1000 watt on Dance floor
 - 6 CP 92 parcans 1000 watt for architectural house lighting

Sound

FOH

- Midas VERONA 32 Channel 8 stereo 8 aux 8 group bus
- Usually configured:
 - Aux 1-5 for a 5 way monitor mix to stage through DN360
 - Aux 6-8 for PCM91/D2/SPX2000
- **Yamaha LS 9 32/64 available by request**

- 12 x L'Acoustics KIVA passive line array speakers
- 4 x L'Acoustics KILO low frequency speaker
- 2 x L'Acoustics SB118 subwoofer speaker 1x18
- 2 x 112Xt Infills
- 3 x L'Acoustics LA4 Amplifier Controller 4x 1000w 4ohm

The system is configured in a left and right formation with 2 KILO and 6 KIVA hung each side at the front of the stage 2 SB118 subs are directly under the stage in the centre coupled together

(Undistorted sound level of the system is 113DB across the entire space)

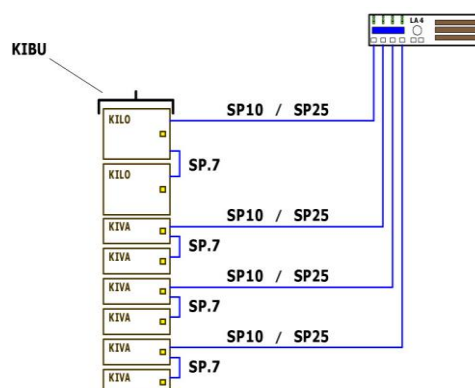

Mic ports on stage are controlled via a 42 patch panel located at the FOH control position

Monitors

6 X Logic Systems LS 151 monitor speakers

3X Yamaha P4500 monitor amps

Please note: The Point does not have a dedicated separate monitor system. Due to the design of the space control from FOH is usually acceptable.

Outboard Equipment

1 x Tascam cd-260 CD player and recorder

5 x Klark Technic DN360 graphic equaliser

1 x Lexicon PCM91 reverb unit

1 x T.C Electronics d-two tap delay

1 x Yamaha SPX 2000 effects unit

10x Drawmer DL241 auto compressor

6x Drawmer DS201 noise gate dual channel

(Tascam CD 160/MD630 are available if booked in advance)

Please note: Although generally reliable ARC does not guarantee trouble free playback of CD/R or CD/RW discs on our CD players. We would generally advise that critical show music is copied to mini disk prior to arrival.

3 x AKG SE300

4 x Shure SM58

4 x Shure SM57

2 x Shure Beta58

3x Shure Beta 57

1 x Shure Beta 91

1 x Shure Beta 52

2 x AKG 451

4 x Sennheiser e604

1 x Beyer M201

1 x Beyer M69

3 x Beyer M88

4 x Sennheiser 421

7 x Audio Technica AT853

6 x EMO 520 DI

1 x BSS ar133 Active DI

1X Cducer Sp Flat

The Point

Communication

Ring intercom c/w 2 belt packs Located at Rear of stage and control position.



For any Further questions or queries please contact the ARC Technical Department

Peter Burgon
Technical and Buildings Manager

T: 01642 525 190

E: peter.burgon@arconline.co.uk

ARC, Stockton Arts Centre Ltd, Dovecot Street, Stockton on Tees TS18 1LL