

Performance Space

Small permanent stage with a front arc and perpendicular sides. SL side 5.5m SR side 6.8m (it's shape can be best described as a wedge shape)

Removable bleacher seating in stalls to allow total flat floor area of approximately 160m²

Space seats 400 in rows and 250 – 350 in various cabaret styles

Fully standing 550

Stage Surface

Strip sprung oak battens with 12mm hardboard painted black with Rosco show varnish

Access

Load-in is from Bright street located behind the venue TS18 1LL , there is a large loading bay once loaded in **ARC does not have any dedicated parking** but local carparks are located close to the venue from £2.80 per day.

Access is at level 1 via a goods lift (2m W x 3m D x 2.6m H) – and doors (2.6m x 2.6m) to rear of stage.

Dressing rooms

Large lockable green room located to the rear of stage with basic kitchen facility's along with comfy seating, mirrors, WIFI, Iron and Hanging rails.

Further dressing rooms/ Storage available on request contact the technical team prior to discuss these options

Rigging

Over stage rigging consists of a fixed litebeam truss hung from 4 500kg manual chain hoists
Maximum flying height >5m.

FOH consists of a fixed lighting bridge accessible from fixed ladders.

Power

- 63A Single phase supply (Production Sound)
- 32A Three Phase
- 32A Single Phase x3 SL
- 16A Single Phase x6 SR(Lighting Power)
- 16A Single Phase x3 SL
- 12x 13 A stage sockets

Sound

Allen and Heath SQ7 with 2 AB168 Stage boxes ,1 Cat-5 FOH-Stage

12 x L'Acoustics KIVA passive line array speakers

4 x L'Acoustics KILO low frequency speaker

4x L'Acoustics SB118 subwoofer speaker 1x18

3 x L'Acoustics LA4 Amplifier Controller 4x 1000w 4ohm

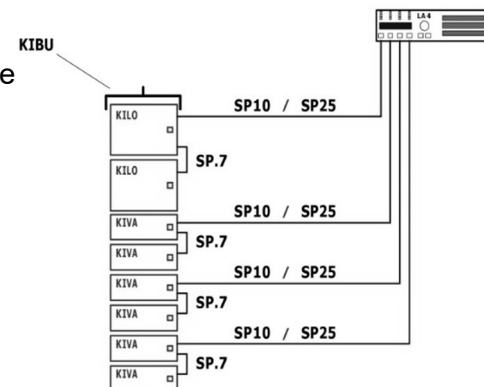

ARC Technical Data Sheet

The Point

The system is configured in a left and right formation with
2 KILO and 6 KIVA hung each side at the front of the stage
4 SB118 subs are directly under the stage in the centre coupled together
(Undistorted sound level of the system is 113DB across the entire space)

Patch Ports

- 1x Cat 5 FOH – Stage
- L/R/SUB fed from FOH
- 6x monitors from stage

Analogue mic ports are available on request

Monitors

6 X Logic Systems LS 151 monitor speakers
3x Yamaha P4500 monitor amps

Please note: *The Point does not have a dedicated separate monitor system. Due to the design of the space control from FOH is usually acceptable.*

Outboard

1x 31 Band KT Available at FOH of required
1 x Tascam cd-260 CD player and recorder
1x Mini disk recorder
Laptops available on request

Microphone stock

The below Microphone stock is available for use within the Point Vocal / Brass microphones are sanitised before and after each show but we highly recommend any Vocalists bring their own Microphones.

5 x Shure SM58
4 x Shure SM57
1 x Shure Beta58
3x Shure Beta 57
1 x Shure Beta 91
1 x Shure Beta 52
2 x AKG 451
2x Shure Beta 87
2x Sennhiser E906
4 x Sennheiser e604
1 x Beyer M201
1 x Beyer M69
3 x Beyer M88
4 x Sennheiser 421
7 x Audio Technica
AT853
6 x EMO 520 DI
1 x BSS ar133 Active DI



Lighting

- The Point is entirely LED and powered via 12 x 16 amp sockets located within the lighting rig.
- Lighting control is from a Chamsys Magic Q 80 with extra wing located at the rear control position running over 4 Universes
- Additional DMX ports are located on stage for floor packages and Hazers
- House lighting is controlled via a 6 way Strand Premiere programmable push button NON DMX

Over stage comprises of:

- 12x Robe 100 Moving heads
- 6 x Chauvet Intimidator spot 350/375Z
- 12x Chauvet Colorado solo 1
- 4x Chauvet Intimidator WZ350
- 6x ETC Color source Par
- 6x Showtec Sun strip (with LED retrofit)
- 10x Chauvet Colour rail (Wall Ascent lighting)

Front of house venue bridges comprises of:

- 6x Prolights WW Profile with 15/32 Zoom
- 2x Prolights TW Fresnel's
- 6x ADJ COB Cannon (Additional House lighting)

Hazers available upon request

Contact the ARC Technical Department to confirm your requirements:

Peter Burgon

Technical Manager

peter.burgon@arconline.co.uk

T: 01642 525 190

Nick Hare

Deputy Technical Manager

nick.hare@arconline.co.uk

T: 01642 525 190