

Performance Area:

Small permanent stage with a front arc and perpendicular sides. SL side 5.5m SR side 6.8m (it's shape can be best described as a wedge shape)

Removable bleacher seating in stalls to allow total flat floor area of approximately 160m²

Space seats 400 in rows and 250 – 350 in various cabaret styles

Fully standing 550

Surface:

Strip sprung oak battens with 12mm hardboard painted black with Rosco show varnish

Access

Access at level 1 via a goods lift (2m W x 3m D x 2.6m H) – and doors (2.6m x 2.6m) to rear of stage **No set storage is available.**

Rigging

Over stage rigging consists of a litebeam truss hung from 4 500kg manual chain hoists

Maximum flying height >5m

Power Supply

63A Single phase supply (Production Sound)

12x 13 A stage sockets

Lighting

The Point is entirely LED and powered via 6x16 amp Sockets located within the lighting rig .

4 way splitters are located at the control position and lighting rig

Lighting control is from a Chamsys Magic Q 80 with extra wing located at the rear control position.

Additional DMX ports located on stage for floor packages and Hazers

House lighting is controlled via a 6 way Strand Premiere programmable push button

Over stage comprises of:

6 x Chauvet Intimidator spot 350/375Z

4x Chauvet Intimidator WZ 350

16x Prolights studio COB pars

8x Chauvet Colorado solo 1

10x Chauvet Colour rail (Wall Ascent lighting)

Front of house venue bridges comprises of:

6x Prolights WW Profile with 15/32 Zoom

4x Prolights TW Fresnel's

6x ADJ COB Cannon (Additional House lighting)

Hazers available upon request

Sound

FOH

Midas VERONA 32 Channel 8 stereo 8 aux 8 group bus

Usually configured:

Aux 1-5 for a 5 way monitor mix to stage through DN360

Aux 6-8 for PCM91/D2/SPX2000

- Yamaha LS 9 32/64 available by request

12 x L'Acoustics KIVA passive line array speakers

4 x L'Acoustics KILO low frequency speaker

2 x L'Acoustics SB118 subwoofer speaker 1x18

3 x L'Acoustics LA4 Amplifier Controller 4x 1000w 4ohm

The system is configured in a left and right formation with 2 KILO and 6 KIVA hung each side at the front of the stage 2 SB118 subs are directly under the stage in the centre coupled together ran from the mono output .

(Undistorted sound level of the system is 113DB across the entire space)

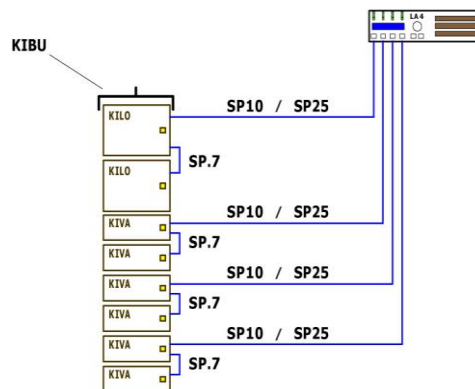

Analogue mic ports on stage are controlled via a 42bay patch panel located at the FOH control position

Monitors

6 X Logic Systems LS 151 monitor speakers

3x Yamaha P4500 monitor amps

Please note: The Point does not have a dedicated separate monitor system. Due to the design of the space control from FOH is usually acceptable.

The Point

Outboard Equipment

1 x Tascam cd-260 CD player and recorder
4 x Klark Technic DN360 graphic equaliser
1 x Lexicon PCM91 reverb unit
1 x T.C Electronics d-two tap delay
1 x Yamaha SPX 2000 effects unit
10x Drawmer DL241 auto compressor
6x Drawmer DS201 noise gate dual channel

Please note: Although generally reliable ARC does not guarantee trouble free playback of CD/R or CD/RW discs on our CD players. We would generally advise that critical show music is copied to mini disk prior to arrival.

5 x Shure SM58
4 x Shure SM57
1 x Shure Beta58
3x Shure Beta 57
1 x Shure Beta 91
1 x Shure Beta 52
2 x AKG 451
2x Shure Beta 87
2x Sennhiser E906
4 x Sennheiser e604
6 x EMO 520 DI
1 x BSS ar133 Active DI
6x Behringer Active DI



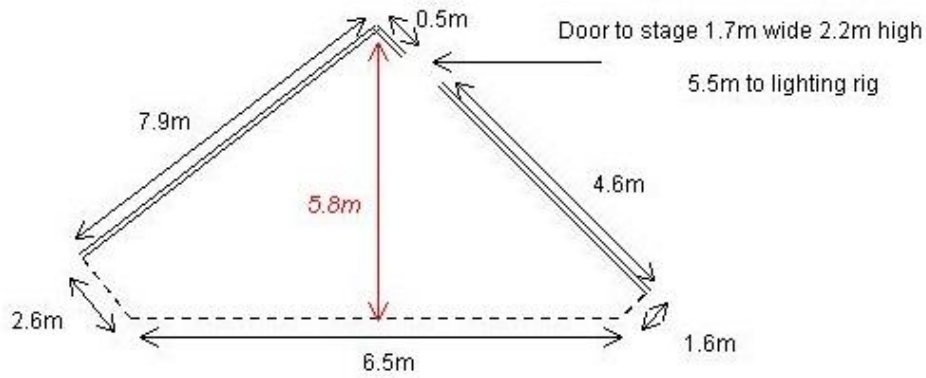

Contact the ARC Technical Department to confirm your requirements:

Peter Burgon
Technical Manager

T: 01642 525 190 E: Peter.Burgon@arconline.co.uk
ARC, Stockton Arts Centre Ltd, Dovecot Street, Stockton on Tees TS18 1LL